

PowerDetektor^{Ar}

Art.no. 13-056 / 13-046

The PowerDetektor feels whether the drilling-/ grinding-/ or weldingmachine etc. are in use, and opens a damper and / or switch the Fan on. Saving energy is a direct result of this, in the shape of less energy consumption and a saving of the heat expenses, because the system is only activated when it is necessary. When the system is switch on automaticly, the use of the spot extractionssystem will also increase, and give a more productive and enviromental workingplace.

6

Effective spot extraction

Geovent PowerDetektor

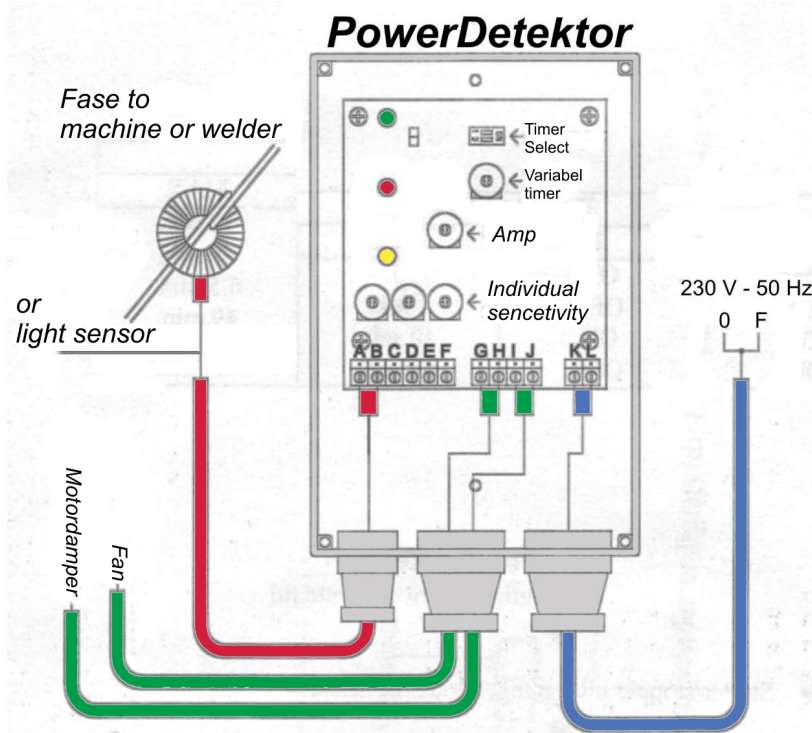

Ordering table for PowerDetektor	
Art. No.	Description
13-046	PowerDetektor - 3 input / 1 output
13-056	PowerDetektor - 1 input / 1 output
13-047	Inductive sensor for PowerDetektor
13-050	IR sensor for PowerDetektor

Features:

- Easy connection/assembly.
- Connection of up to 3 machines (only 13-046).
- Sensitive adjusting of each sepatated mashines.
- Optional extraction retention delay within a variable timeperiod.
- Switch on the system automately, save energy and furthermore the system is used more, so an improved workingplace is obtained.
- Flexible mount of the Indusive sensor/IR sensor.

Timer select			
1	2	MIN	MAX
OFF	ON	0	12 sek.
ON	OFF	1 sek.	49 sek.
ON	ON	10 sek.	6,5 min.
OFF	OFF	80 sek.	49 min.

GEOVENT

Hovedgaden 86
8831 Løgstrup
Telefon: 86 64 22 11
Telefax: 86 64 30 75
email: salg@geovent.dk
www.geovent.com



Maj 2002